

TINY-L series

Flashlamp-pumped Compact Nd:YAG ns-laser



FEATURES

- compact design and **Fast lamp changing unit**
- **50-200mJ** at 1064nm / Harmonics from 532nm to 266nm
- **10-30 Hz** repetition rate / **4-5 ns** pulse duration
- Compact and rugged resonator structure ensures long-term thermal and mechanical stability
- **Harmonics with cartridge holder type unit** require no extra space for installation
- RS232 interface for remote operation

TINY-L series provide most compact and portable flashlamp pumped nanosecond lasers with high performance and at a very reasonable price. Fast lamp changing unit and cartridge holder type harmonics design make it easier to operate.

APPLICATIONS

- LIDAR
- LIBS
- Remote sensing
- Ablation
- Mass spectroscopy

TINY-100L 355nm Laser Head

Mechanical Specifications

Unit:mm

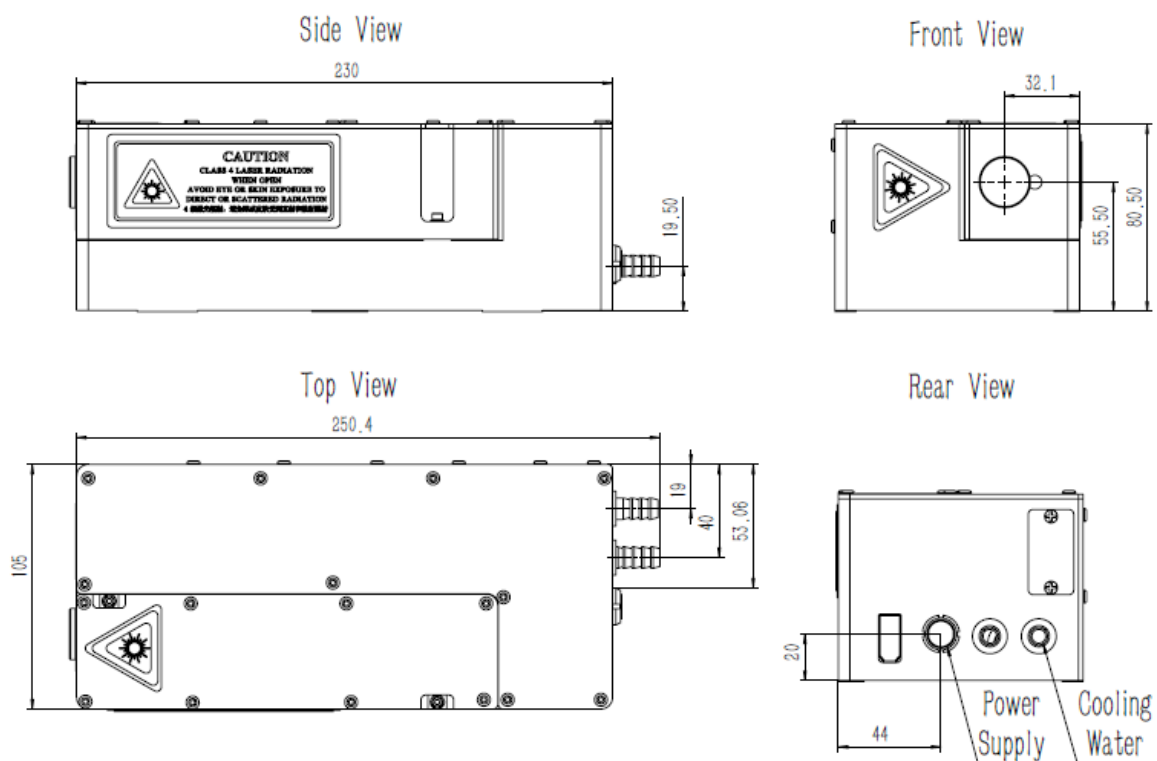

Flashlamp-pumped Compact Nd:YAG ns-laser

Beam characteristics

Version	TINY-50L	TINY-100L	TINY-200L
Repetition Rate ¹ (Hz)	1-30Hz	1-20Hz	1-10Hz
Energy (mJ)			
1064nm	50	100	200
532nm	25	50	100
355nm	10	30	60
266nm	5	10	20
Energy Stability RMS (%)			
1064nm	1%		
532nm	1.7%		
355nm	3%		
266nm	3.5%		
Power Drift ² (%)			
1064nm	3%		
532nm	5%		
355nm	8%		
266nm	10%		
Pulsewidth FWHM ³ (ns)	4-5ns @1064nm		
Divergence ⁴ (mrad)	<1mrad		
Beam Pointing Stability ⁵ (μrad)	50μrad		
Timing Jitter RMS ⁶ (ns)	<1ns		
Beam Diameter (mm)	~4	~5	~6
Transverse Mode ⁷	GRM mode (Top hat)		
Polarization	linear		

General characteristics

AC Input	220 VAC ±5% 50-60Hz
Power Consumption	<800W (typical 100mJ at 20Hz)
Operating Conditions	Temperature 10-35°C Humidity <60%
Warm Up Time	<10min

NOTES

- 1.All specifications at 1064nm and 10Hz repetition rate unless otherwise noted.
- 2.Average in 8 hours with room temperature variation $\delta T < 3^{\circ}\text{C}$.
- 3.Full width at half maximum.
- 4.Full angle for 86.5% of energy.
- 5.Represents RMS value deviation from beam mean centroid.
- 6.With respect to external trigger.
- 7.GRM resonator mode or stable multimode option. Stable version may operate over a wider range of repetition rate and higher output energy compared with GRM mode.

Grace Laser Technology Co., Ltd.

Ju Hong BLDG B, Area B, Airport Industrial Park, Shunyi District, Beijing, China

Postcode: 101318

Tel: +86 010-60401920 Fax: +86 010-60401720 Email: sales@gracelaser.com

Web: www.gracelaser.com

